



Shaping The Future Of Education

Adult Learner Handbook

2023-2024

Volume 31

Spring, 2023

Early Childhood Montessori Teacher Education

Infant & Toddler Montessori Teacher Education

**Montgomery Montessori Institute
10500 Darnestown Road
Rockville, Maryland 20850
301-279-2799
info@TeachMontessoriMMI.com
TeachMontessoriMMI.com**



Faculty & Admission

Course Director

Aline Feledy

Early Childhood

Instructors

Margaret Akatu	Betsy Newman
Kalani Brown	Saadia Perwaiz
Tory Enerson	Mary A-Speakman
Aline Feledy	E.Wilson Wulfekotte
Gwen Hines	

Infant & Toddler

Instructors

Elyssa Boulet	Gwendolyn Horton
Kalani Brown	Betsy Newman
Aline Feledy	Saadia Perwaiz
Diana Hashem	Mary A-Speakman
Gwen Hines	Laveeta Sweeney
	E.Wilson Wulfekotte

Board of Directors

Pamela W. Trumble and Aline Feledy

Established by Lillian Oboler, Marian Pepper, and Pamela W. Trumble

Montgomery Montessori Institute is approved by The Maryland Higher Education Commission.

Montgomery Montessori Institute has carefully designed its courses to meet the teacher education standards of the American Montessori Society. Montgomery Montessori Institute's Teacher Education Courses are affiliated with the American Montessori Society (AMS) and accredited by the Montessori Accreditation Council for Teacher Education (MACTE).

Montgomery Montessori Institute does not practice discrimination on the basis of age, gender, race, color, religion, national and/or ethnic origin, or disability in the admission of students, the employment of faculty or administrative staff, or in the administration of its policies.

Montgomery Montessori Institute is committed to maintaining a code of ethics and fair practice with all who participate in our courses, students and faculty alike.

Montgomery Montessori Institute is owned and operated by Montgomery Montessori Institute, LLC.

Table of Contents

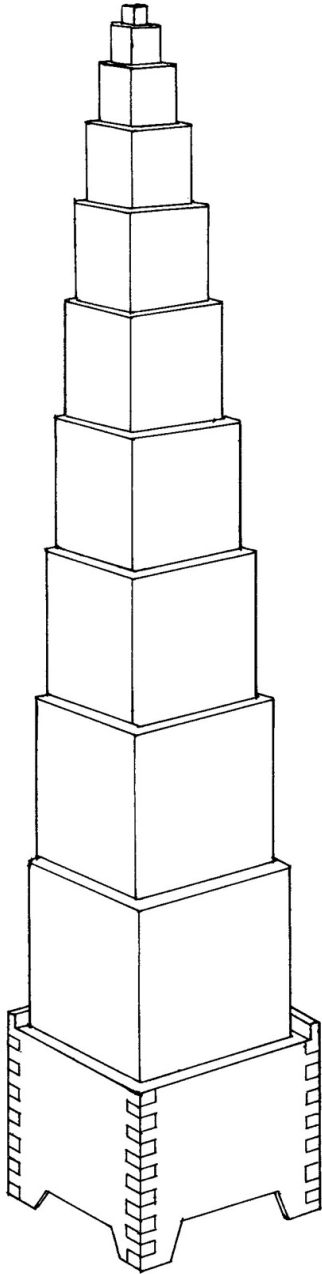

Mission Statement	1
Course Descriptions	1-2
Practicum Site Overview / Completion of MMI / Books	3
The Facility / The Community Around the Campus	4
Academic Phase Daily Schedule / AMS Credential	5
Enrollment Procedure / Transfer Policy	6
Class Schedule	7
Tuition and Fees	8
Late Payments / Adult Learner Services	9
Attendance Policy	10
Rights, Privileges & Responsibilities / Records	11
Grading & Grade Reports / Graduation Requirements	12
Academic Standards & Progress	13
Grievance Procedures	14
Withdrawal or Dismissal / Extension Policy	15
Cancellation of Courses	16
Early Childhood Teacher Education Course	16-18
Early Childhood Academic Phase Schedule	19
Early Childhood Practicum Phase & Exam Schedule	20
Infant & Toddler Teacher Education Course	21-22
Infant & Toddler Schedule of Classes	23
Infant & Toddler Practicum Phase & Exam Schedule	24-26
MACTE Competencies	27
AMS Code of Ethics	28
Fundamental Tenets of an AMS Affiliated TEP	29
Acknowledgement of Receipt of Adult Learner Handbook	30



Montgomery
Montessori
Institute

Shaping The Future Of Education

Mission Statement

Montgomery Montessori Institute has established carefully designed Early Childhood and Infant & Toddler teacher education courses in response to the critical community and nationwide need for qualified and inspiring Early Childhood educators and Infant & Toddler professionals. Anchored in the teaching philosophy and teaching methodology formulated by Dr. Maria Montessori, the **MMI** courses focus on the developmental needs of the child within a context of respect, freedom and structure.



Course Descriptions

Recognizing that children from birth through six, grow through developmentally sensitive periods, **MMI** adult learners study in a rigorous educational environment combining Montessori theory and philosophy, observational research, and practical classroom teaching skills. Empowered with a thorough understanding of children's developmental needs, **MMI** graduates are professionally educated to subsequently endow their infants, toddlers, and early childhood students with the art, inventiveness and creativity of learning in a 21st century high-tech, fast-paced world.

A minimum one-to-ten teacher-adult learner ratio is maintained throughout both teacher education courses. **MMI** has a three-fold objective of educating, credentialing, and assisting Montessori graduates in placing them locally or in Montessori schools nationwide. The Montessori teacher credential is achieved through successful completion of **MMI's** two-phased program.

- The Academic Phase
- The Practicum Phase

Early Childhood Teacher Education Course

The Course consists of 354 **Academic Hours**, that take place primarily during the concentrated eight week summer session. During the Academic Phase adults learn through a combination of lectures, discussions, demonstrations, and observation of active classroom experiences. The curriculum at Montgomery Montessori Institute offers the adult learner extensive background knowledge in all the areas necessary to successfully guide an early childhood classroom. Course work during the Academic Phase covers the areas of Montessori philosophy, child development, observation and research techniques, language, math, sensorial activities, practical life, social studies/geography, physical and life science, art, music, movement, and classroom management and administration.

Adult learners enter the **Practicum Phase** following the Academic Phase. During the Practicum Phase adult learners work in the classroom of an approved supervising teacher, for a minimum of three hours a day, five days a week for nine consecutive months for at least 540 hours of instructional class time. Additional 72+ Practicum hours consist of Practicum Seminars held at **MMI** and research-based independent study. Throughout the Practicum Phase a Practicum Supervisor, working in conjunction with **MMI**, serves as advisor, classroom observer, and liaison between the adult learner, the Supervising Teacher, and Montgomery Montessori Institute. The intern is visited a minimum of three times throughout the Practicum Phase by the Practicum Supervisor. Adult learners holding a Bachelor's degree and who have completed either two or more years of previous teaching experience at the early childhood level or prior experience as an assistant in a Montessori early childhood classroom, may apply to the Course Director to participate in a self-directed internship. A minimum of three Practicum Site visits plus documented additional support is required during the self-directed Practicum. Practicum sites are available locally.



Infant & Toddler Teacher Education Course

The Course consists of 230 **Academic Hours**, that take place primarily during the concentrated five week summer session, plus five Saturdays in the fall and winter. During the Academic Phase adults learn through a combination of lectures, discussions, demonstrations, and observation of active infant and toddler environments. The curriculum at Montgomery Montessori Institute offers the adult learner extensive background knowledge in all the areas necessary to successfully prepare and guide a variety of infant and toddler settings. Course work during the Academic Phase covers the areas of Montessori philosophy, infant and toddler pedagogy; child development; observation and research techniques; the child, family and community; environmental design and curriculum; program leadership and administration; and personal growth and development.

Adult learners enter the **Practicum Phase** following the Academic Phase. During the Practicum Phase adult learners work in the environment of an approved supervising guide, for a minimum of three hours a day, five days a week for nine consecutive months for at least 540 hours. Additional Practicum hours consist of Practicum Seminars held at **MMI** and at other nearby locations, plus preparation of a research-based independent study. Throughout the Practicum Phase a Practicum Supervisor, working in conjunction with **MMI**, serves as advisor, observer, and liaison between the adult learner, the infant or toddler Guides, and Montgomery Montessori Institute. The intern is visited a minimum of three times throughout the Practicum Phase by the Practicum Supervisor. Adult learners holding a Bachelor's degree and who have completed two or more years of prior experience as an assistant in a Montessori infant or toddler environment, may apply to the Course Director to participate in a self-directed internship. A minimum of three Practicum Site visits plus documented additional support is required during the self-directed Practicum. Practicum sites are available locally.

Practicum Site Overview

All Practicum Sites and Supervising Teachers must meet the standards of the American Montessori Society and be pre-approved by the Course Director. Pre-approval includes a meeting with the school Administrator and touring the school to insure that the school meets the AMS guidelines for Practicum Sites. **MMI** will assist in locating a practicum site for each adult learner. Practicum sites outside the Washington, D.C. metropolitan area may be facilitated by a local mentor teacher plus an approved Practicum Supervisor affiliated with a MACTE-accredited teacher education course. Practicum sites more than a 1½ hour drive from either a local or out of area Montessori institute must be approved by the Program Director. The cost of out of area site visits are to be arranged between the **MMI** adult learner and the Program Director prior to the beginning of the Practicum Phase.

The following forms listing the Practicum Site requirements and the Supervising Teacher requirements and responsibilities are included in the appendix at the back of the MMI Catalog: 1. Practicum Site Agreement – Infant & Toddler, 2. Practicum Site Agreement – Early Childhood, and 3. Standards and Responsibilities for the Supervising Teacher.

Monitoring of Practicum Sites includes touring the school and meeting with the school Administrator prior to approval of the school. A school that has not served as a Practicum Site in more than two years or that has had a change of location or administration must be re-approved as a Practicum site, following the same procedure.

With each and every new intern, the *Practicum Site Agreement* and the *Standards and Responsibilities for the Supervising Teacher* must be signed.

During the Practicum Phase adult learners have the choice of either serving in a volunteer capacity or being compensated by the practicum site. Adult learners gain experience in preparing learning environments, developing observation and research skills, presenting lessons, planning strategies for classroom management, keeping records, and participating in events designed to improve parent and staff development. Adult learners are also required to attend scheduled **MMI** Saturday seminars throughout the Practicum Phase. Some of the written and oral/practical exams are held during the Practicum Phase.

Upon Completion of MMI Courses

Adult learners completing the entire Early Childhood Course or Infant & Toddler Course will have the ability to plan and implement learning activities in all the major curriculum areas found in Montessori environments and classrooms. Both courses are designed to prepare candidates to meet all related MACTE competencies. Application of the Montessori philosophy and the basic techniques of classroom management and environmental design result in a graduate who recognizes that infants and children have different needs, learning styles, and varying rates of growth and development. Through effective communication with parents and faculty, the **MMI** graduate is well prepared to guide each child in reaching his/her fullest potential.

Current adult learners and prospective adult learners of **MMI** may obtain information regarding the enrollment, completion, and placement rates of the **MMI** Infant & Toddler Montessori Teacher Education Course or the Early Childhood Montessori Teacher Education Course from the Maryland Higher Education Commission.

Maryland Higher Education Commission
6 N. Liberty Street, 10th floor
Baltimore, Maryland 21201
410-767-3300
800-974-0203
www.mhec.state.md.us

Books and Supplies

All required books and supplies are provided to the adult learner following payment of the Text, Album, and Association Fee. The adult learner creates albums and classroom materials that serve as resources for use during the Practicum Phase and beyond, therefore, the adult learner should allow a minimum of \$100 for material-making supplies.



The Facility

Montgomery Montessori Institute (**MMI**) is located at 10500 Darnestown Road in Rockville, Maryland. **MMI** is a Montessori Teacher Education Program housed on the campus of the Franklin Montessori Schools: Franklin Montessori School and Franklin Country Day Montessori School, Montessori schools approved by the Maryland State Department of Education and accredited by the American Montessori Society. The summer Academic Phase is held within classrooms designated for Montgomery Montessori Institute.

Two large classrooms and a small toddler environment create a combined meeting area and classroom space fully equipped with the traditional Montessori materials and equipment. An integral and unique feature of our training course is the opportunity to observe mixed age groups of children, three-months through six years, in the adjacent classrooms of the Franklin Montessori Schools. During the summer Academic Phase Montessori classrooms and environments are in session where adult learners may observe infants and young children as they work, play, and learn.

Additional opportunities are scheduled for **MMI** Infant & Toddler adult learners to visit and observe various infant and toddler settings in home environments as well as childcare and school settings.

Montgomery Montessori Institute provides access to numerous teacher resources, including copy machines, laminators, paper cutters, and other musts for designing and creating classroom materials. There are several computers and printers available for use by adult learners as well as access to wireless internet. We have many comfortable areas indoors and on our beautiful grounds for students to enjoy lunch and group study times. A small kitchen is available for adult learner use.

MMI has several hundred teacher reference books and periodicals specifically related to infancy through the early childhood years. There is also an extensive children's library available on-site with both print and non-print materials including science and social studies units.

Classrooms are available during the Academic Phase to provide adult learners ample opportunities for designing, constructing, equipping, and critiquing original age-appropriate settings.

The school and **MMI** offices act as a clearinghouse of information. It is here that all adult learner records are maintained. The Staff Lounge offers ample room for appointments with faculty and group conferences.

The Community Around the Campus

MMI is located in Rockville, Maryland, approximately 12 miles from downtown Washington, D.C. and Northern Virginia. There is a bus stop in front of **MMI** that follows many bus routes leading to shopping and entertainment throughout the area. **MMI** is five miles from the Rockville Metro Station that is accessible by bus and car. With Washington, D.C. about a forty-minute drive or a Metro ride from **MMI**, adult learners take advantage of the nation's capital, its shops, museums and historic sights.

Academic Phase Daily Schedule

Classes begin promptly at 8:00 a.m. and end at 5:00 p.m. There is a one-hour lunch break at noon each day. The classroom time consists of lecture, discussion, demonstration, observation, material making, and opportunities for practice in classroom and environment settings. Although material making and practice are built into the daily schedule, additional time is needed for these activities as well as for reading and study. Material making continues through the Practicum Phase to allow adult learners more time and resources for completion of assignments. **MMI** opens at 7:00 a.m. each day and closes at 6:30 p.m. Adult learners are welcome to use the time before and after class for discussion, study, and practice. Coffee, tea, and light snacks are available throughout the day. Adult learners are encouraged to bring lunch. A refrigerator and a microwave are available for your use.



The American Montessori Society (AMS) Credential

Upon successful completion of the Course, the candidate holding at minimum a Bachelor's degree from a regionally accredited U.S. college/university or its equivalent from a non-U.S. college/university is recommended by the **MMI** Program Director to receive an AMS credential at the level of study – Early Childhood or Infant & Toddler. (Note that the Infant & Toddler credential requires that the candidate hold either a Montessori Early Childhood Credential issued by an AMS or another MACTE-accredited course, or the alternative, the MMI Prerequisite Overview Course.)

Upon successful completion of the Course, the candidate holding at minimum a Bachelor's degree from a non-U.S. college/university and whose Bachelor's degree does **not** equate to that of a U.S. Bachelor's degree from a regionally accredited U.S. college/university may choose to have indicated on the recommended AMS credential the degree and country in which the graduate was awarded the Bachelor's degree.

Upon successful completion of the course, the candidate holding a high school diploma or GED, but not a Bachelor's degree is recommended by the **MMI** Program Director to receive an Associate AMS credential at the level of study – Early Childhood or Infant & Toddler. Country, state and local employment requirements vary widely and change periodically. In addition, employment requirements vary in different types of schools (e.g. private, public/charter, faith based, publicly funded). In some locations or schools, an Associate Credential may not qualify for full teaching responsibility. In the state of Maryland, Montessori teachers must hold at minimum a Bachelor's degree. The applicant is responsible for confirming the teaching requirements in specific jurisdictions and schools.

Applicants for the AMS Early Childhood or Infant & Toddler course, who do not have a U.S. Bachelor's degree from a regionally accredited U.S. college/university or its equivalent are required to sign a statement verifying that they have received the above information before they are considered for acceptance into **MMI**. AMS strongly encourages holders of the AMS Associate Early Childhood Credential or of the AMS Associate Infant & Toddler Credential to obtain their Bachelor's degree within 5 years of credentialing. AMS hopes holders of an Associate credential consider the credential as the beginning of a journey of lifelong learning. Teachers with an Associate credential are eligible for an AMS Early Childhood Credential or for an Infant & Toddler Credential upon completing the Bachelor's degree requirement. To upgrade an AMS credential, the candidate must be a current AMS member and send an official transcript documenting the Bachelor's degree with the credential upgrade fee to the AMS Office of Teacher Education.

The AMS Montessori teacher credential is issued for life. To keep the credential active, 50 hours of professional development must be completed every 5 years. If professional development hours are not completed within each 5-year period, the teacher's credential will be considered inactive until the requirement is met. Approved professional development is available on the AMS website.



*As soon as children find something that interests them
they lose their instability and learn to concentrate.*

Maria Montessori

Enrollment Procedure

Applicants wishing to enroll in Montgomery Montessori Institute should complete the following steps:

- Submit to **MMI** the Application, your resume, a short essay, and the \$150 Application Fee.
- Submit to **MMI** two official transcripts for each college or university attended.
- Submit, or have submitted to **MMI** three letters of recommendation with cover sheet.
- Read, sign, and submit to **MMI** the American Montessori Society (AMS) Associate Credential Policy Statement.
- Complete an interview with the **MMI** Program Director.
- Experience in Early Childhood Education or in an Infant & Toddler setting is not a prerequisite for admission.
- Upon receipt of the required items, adult learners will receive written notice regarding admission to Montgomery Montessori Institute. All adult learners are required to sign the **MMI** Enrollment Agreement to formalize admission.

Once arrangements for a Practicum Site have been made the adult learner must:

- Submit to **MMI** a copy of a completed *Medical Report for Staff In Child Care Centers* or an equivalent document.
- Provide evidence of a state and/or federal background check.
Adult learners should be aware that criminal convictions might affect their ability to be licensed by the Maryland Office of Child Care or to be hired by a licensed facility.



Transfer Policy

Transfer of a current adult learner from one AMS-affiliated teacher education program to **MMI**, requires the candidate be within the two-year time limit following the original Academic Phase and be a member of AMS. Previously completed academic and practicum work is reviewed and evaluated by **MMI** and the original teacher education program is contacted to determine if the adult learner is in good standing academically and financially.

Transfer of contact hours and/or credits from other teacher education programs recognized by AMS will be considered with verification of the following documentation: provide a degree in keeping with AMS credential requirements, hold a current AMS membership or be registered as an adult learner; review and evaluation of the current credential and portfolio; undergo proficiency pretesting to plan a program of study; determine minimum requirements of both the Academic and Practicum phases to meet **MMI**'s requirements; and assessment and evaluation of proficiency as required by **MMI**.

Tuition is based on the portion of the course to be completed at **MMI**. All transfer candidates must take *Montessori Philosophy and Theory* at **MMI**.

Transfer of credits, including distance education credits from Montessori programs not recognized by AMS are not accepted.

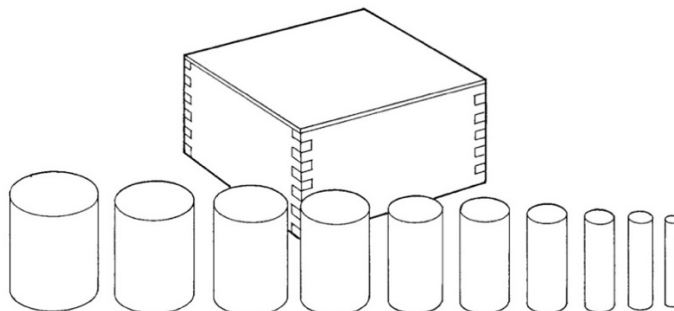



Class Schedule 2023-2024

Early Childhood

Academic Phase

Monday, June 12 – August 4, 2023
Monday - Friday
8:00 a.m. to 5:00 p.m.
MMI will be closed Tuesday, July 4th

*Dates are subject to change due to
Covid regulations

Practicum Phase Internship

September through June
a full academic year 2023-2024
Hours, times and dates dependent on the
adult learner and the approved internship site.

Practicum Seminars

9:00 a.m. to 4:00 p.m.
One Saturday per month,
from September through June

Dates to be Announced

Oral Exam Week

Second Summer: June 24 - June 27, 2024
Monday - Thursday
9:00 a.m. to 5:00 p.m.

The course comprises a total of 840+ hours
to include
354 instructional clock hours.

Graduation Date
Thursday, June 27, 2024

Infant & Toddler

Academic Phase

Monday, June 12 - July 14, 2023
Monday - Friday
8:00 a.m. to 5:00 p.m.
MMI will be closed Tuesday, July 4th

*Dates are subject to change due to
Covid regulations

Overview Course (if required)
Date to be Announced

Practicum Phase Internship

September through June
a full academic year 2023-2024
Hours, times and dates dependent on the
adult learner and the approved internship site.

Practicum Seminars

9:00 a.m. to 4:00 p.m.
One Saturday per month,
from September through June

Dates to be Announced

Exams

December
June

The course comprises a total of 770+ hours
to include
230 instructional clock hours.

Graduation Date
Thursday, June 27, 2024



Tuition & Fees

The **MMI** Teacher Education Course tuition and fees are itemized below. Adult learners must meet all financial obligations to be eligible to receive the **MMI** Certificate of Completion and the AMS teaching Credential.

	Date due	Early Childhood	Infant & Toddler
Application Fee	with application	\$150	\$150
Academic Phase Tuition	May 31	\$5,300	\$4,300
Text, Album & Association Fee	May 31	\$1,500	\$1,200
Overview Course: Infant & Toddler adult learners not holding an EC credential	August 15	n/a	\$500
Practicum Phase Tuition: (select one) includes 3 practicum site visits	August 15	Select one	
1) With a AMS Certificated Head Teacher		\$2,000	\$2,000
2) Self Directed Practicum Phase Tuition		\$2,300	\$2,300

* Adult learners should allow at minimum \$100 for material making supplies.

Additional metropolitan area Practicum Site Visits - \$75 per visit due upon receipt. **Out of area Practicum Site Visits** cost will be arranged between the adult learner and **MMI** Course Director prior to the beginning of the Practicum Phase. **MMI** does not offer financial aid. Information about AMS & Maryland Scholarships is available upon request.

All application fees, tuition, and other fees paid by an adult learner shall be refunded if the adult learner chooses not to enroll in or to withdraw from **MMI** within 7 calendar days after having signed the Enrollment Agreement. Notice of withdrawal shall be given in writing. Refunds are made within 60 days. If the adult learner chooses not to enroll after the 7-day cancellation period but before the first day of instruction, **MMI** may retain the Application Fee.

If an adult learner withdraws after the 7-day cancellation period, refunds shall be based on the percentage schedule below. If an adult learner withdraws after instruction begins, refunds shall be based on the total contract price for the Phase and shall include all fees, except the Application Fee and the Text, Album, and Association Fee, and any charges for books, materials, or supplies which have been purchased by, and are the property of, the adult learner.

If an adult learner withdraws from the **MMI** Academic Phase before 50% of the phase has been presented, a refund based on the date of withdrawal or termination shall be paid within 60 days from the date of withdrawal or termination (the last date of attendance by the adult learner) and following the schedule below. If an adult learner withdraws from the **MMI** Practicum Phase before 50% of the phase has been presented, a refund based on the date of withdrawal or termination shall be paid within 60 days from the date of withdrawal or termination (the last date of attendance by the adult learner) and following the schedule below.

In the case of an official leave of absence, if an adult learner fails to return to **MMI** by the end of the leave of absence, a refund due the adult learner shall be based on the date of withdrawal or termination and paid within 60 days of the scheduled last day of the leave of absence.

<u>Portion of Phase taught by date of withdrawal</u>	<u>Tuition refund</u>
Less than 10%	90% refund
10% up to but not including 20%	80% refund
20% up to but not including 30%	60% refund
30% up to but not including 40%	40% refund
40% up to 50%	20% refund
More than 50%	No refund

Late Payments

No extensions or delays in tuition payment are recognized unless issued in writing by the **MMI** Program Director. Late payments will accrue simple interest at the rate of 8% a year on the unpaid balance.

"Any holder of this Consumer Credit Contract is subject to all claims and defenses which the debtor could assert against the seller of goods or services obtained pursuant hereto or with the proceeds hereof. Recovery hereunder by the debtor shall not exceed amounts paid by the debtor hereunder."

Returned checks will be assessed a service charge of \$25.



Adult Learner Services

Placement

Montgomery Montessori Institute will make every effort to aid its graduates in finding positions suitable for working with infants and toddlers or in early childhood classrooms according to level of study. **MMI** is available to help with counseling in the preparation of adult learner resumes. The Course Director will furnish both personal and academic references upon request. Available employment positions are posted via email as they are received by Montgomery Montessori Institute. Although every effort will be made to assist our adult learners through the process of targeting job openings and presenting themselves professionally, Montgomery Montessori Institute can not guarantee job placement, employment, salary, or occupational advancement for its graduates.

Tutoring

Adult learners can make appointments to meet with instructors or administrators of **MMI** to discuss school related issues through the office. Tutoring by **MMI** faculty is available at the rate of \$50 per hour. Fees are due upon receipt of services.

Miscellaneous

Child Care: Childcare referrals may be available in the **MMI** office. Under no circumstances can children stay in any classes, lectures, lounge areas, or resource rooms at **MMI**.

Clothing: The dress code at **MMI** is a casual one, but please remember that you will be in school classrooms and will want to dress in an appropriate and professional manner. Keep in mind the hot humid nature of Maryland summers. Although our facility is air conditioned, outside activities can be uncomfortable.

Health Care: Should a health emergency arise, Shady Grove Adventist Hospital is approximately two miles away.

Money: **MMI** will accept personal checks for payment of tuition or other classroom materials. The office cannot, however, cash checks for personal needs. **MMI** cannot provide security for valuables or be responsible for loss.

Maintenance: Janitorial service is provided throughout the facility. As professionals, adult learners are expected to clean up after themselves and to demonstrate care and respect of the classroom environments.

Attendance Policy

All adult learners must have at least a 90% attendance rate for all classes and seminars and complete 100% of the required minimum student teaching hours during the Practicum Phase in order to receive certification from **MMI** and the AMS Early Childhood or Infant & Toddler Credential. All class time must be accounted for by an authorized **MMI** faculty member and attendance records are maintained.

MMI encourages 100% attendance. Each faculty member keeps regular attendance records. Unexcused absences during the Early Childhood Academic Phase that exceed 25 instructional hours receive a written warning; absences totaling 31 hours are evaluated on an individual basis, as certification may not be possible. Unexcused absences during the Infant & Toddler Academic Phase that exceed 16 hours receive a written warning; absences totaling 20 hours are evaluated on an individual basis, as certification may not be possible.

Absences may occur due to illness or personal circumstances. All absences must be cleared with the instructor and the Course Director. Adult learners should contact **MMI** as soon as they know they will be absent. The Absence Form must be submitted in advance or immediately upon return. Our instructors and the Course Director will make every effort to assist adult learners in making up missed time. Make up assignments must be relevant in nature and content to the material missed and may not total more than 10% of the Academic Phase. The procedure for making up missed class time is as follows:

- Adult learner submits the Absence Form with a plan to make up work with the instructor.
- Class notes from lectures can be obtained from another adult learner or the instructor. At the discretion of the instructor, a relevant written assignment or other independent project may be assigned to further supplement the missed information.
- Missed lesson demonstrations may require tutoring to develop expertise in use of materials and equipment. Both the adult learner and the instructor must agree upon the amount of tutoring required.

If an adult learner misses more than two sessions of any course he/she may be required to retake that course the following summer. If an adult learner misses more than a week of the Early Childhood class or 20 hours of the Infant & Toddler class, arrangements must be made with the Course Director to retake missed course work the following summer. A plan to bring attendance to the required 90% must be on file prior to entering the Practicum phase. **MMI** classes begin promptly at the scheduled time and tardiness is not acceptable. Hours lost through **tardiness or early departure will be recorded and treated in the same way as an absence**. Authorized make up time will be required.

The Practicum Phase internship must consist of a minimum of **540 hours** of instructional class time to meet the requirements for the Early Childhood Credential and a minimum of **540 hours** completed over a nine-month period for those seeking the Infant & Toddler Credential. If attendance becomes a problem during the internship, arrangements will have to be made for make up time that is suitable to **MMI**, AMS and the internship site.

Adult learners may apply in writing to take an official leave of absence from **MMI**. During the length of the course, there may be one official leave of absence that may not exceed 180 cumulative days. The adult learner is required to provide a written, signed, and dated request for a leave of absence, which is documented in the adult learner's file.



*The most important period of life
is not the age of university studies
but the period from birth to the age of six...
for that is the time when intelligence itself,
her greatest implement, is being formed...*

María Montessori

Rights, Privileges and Responsibilities

Montgomery Montessori Institute is committed to maintaining a code of ethics and fair practice with all who participate in our courses, adult learners and faculty alike. Adult learners are expected to maintain appropriate professional conduct during both the Academic and Practicum Phases. Polite, courteous, and considerate conduct is expected at all times. In the event of inappropriate conduct, every effort will be made with the Course Director to resolve the problem in a timely way mutually acceptable to both parties. However, disruptive, irresponsible, or unprofessional conduct can be considered grounds for dismissal from the Course.

Montgomery Montessori Institute is located at the site of Franklin Montessori Schools. Children between the ages of 3 months and six years are enrolled at the school while **MMI** is in session. The Maryland State Department of Education, the Franklin Montessori Schools, and Montgomery Montessori Institute do not allow use of any drugs or alcohol at this location. **Use of drugs or alcohol anywhere on the premises is strictly prohibited.** Smoking inside our facility or on the school grounds is not permitted.

The American Montessori Society requires that all affiliated teacher education programs agree to comply with the AMS Code of Ethics. As American Montessori Society educators we strive to conduct ourselves professionally and personally, in ways that reflect our respect for one another and for the children we serve; and we will do whatever is within our talents and capacity to protect the right of each child to have the freedom and opportunity to develop his or her full potential.



Adult Learner Records

Permanent records are maintained regarding admission, attendance, and evaluation. Permanent transcripts documenting adult learner progress are also permanently maintained. All adult learners have the right to privacy. Confidentiality and access to records are guaranteed in accordance with the Family Educational Rights and Privacy Act (FERPA).

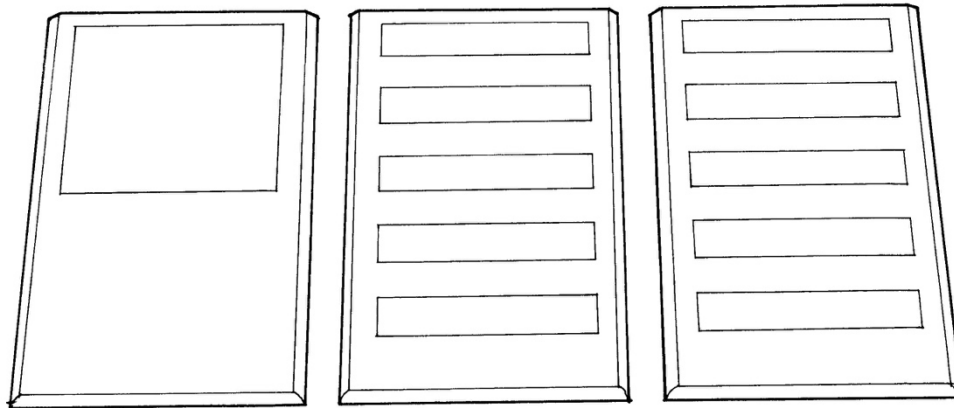

Grading and Grade Reports

A progress sheet is kept that lists the adult learner's assignments, exams, and participation. Upon completion of all requirements for each course, the adult learner's academic achievement and daily attendance are recorded on the individual adult learner Permanent Record Form. A check mark (✓) indicates a successfully completed assignment. When letter grades are given, they are assigned as follows:

O = Outstanding:	core of 90% and above
S = Satisfactory:	Score of 75% to 89%
F = Failure:	Score below 75%

Progress is monitored both formally and informally on a daily basis. The following is a percentage break down of the weight of assignments, albums, examinations, class participation, and attendance toward a student's final course grade.

Assignments	30%
Album	20%
Written examination	20%
Oral examination	20%
Class participation & attendance	10%

Adult learners must have a final grade of Outstanding, Satisfactory, or a check mark in every course. Each assignment, album or exam grade must stay at or above 75%.

In order to be complete and be recommended for credential, an adult learner must have a minimum grade of Satisfactory or a check mark and 90% attendance in all courses and seminars.

Adult learners receive progress evaluations during the week after the last day of each course during the Academic Phase as recorded on the course Grading Sheet. If a student has questions about grades or progress at anytime, this information is available from the Instructor, the Course Director or the Program Director.

In order to take the Oral Practicum Exams, adult learners must have submitted all albums and written assignments with sufficient time allowed for assessment. Oral examination grades are available on the day of the exam. Written examination grades are provided within 7 days of the exam.



Graduation Requirements

- Payment of all financial obligations to Montgomery Montessori Institute
- Completion of both the Academic and the Practicum Phases
 - Early Childhood: Academic Phase: 380 academic hours + 540 Practicum hours = 920 hours
 - Infant & Toddler: Academic Phase: 230 academic hours + 540 Practicum hours = 770 hours
 - Note: Infant & Toddler candidates who do not hold a Montessori Early Childhood teaching credential are required to complete the 24-hour MITE-OV: 6.1.5.0. Prerequisite Overview Course
- 90% attendance rate for all classroom and seminar hours
- Completion of all required documents and forms
- Submission and approval of all assignments and albums
- Satisfactory completion of written and oral evaluations for both the Academic and the Practicum Phases

Academic Standards and Progress

Written notice of academic probation occurs when:

- Adult learner's attendance is below 90%
- Adult learner's grade is no higher than 75% in any course

When academic probation occurs, the adult learner is notified in writing of the required make-up work and is offered academic counseling by an instructor or the Course Director. The adult learner is given the option to complete or retake course work in the next Academic Phase or Practicum Phase cycle.

Written notice of suspension occurs when:

- The adult learner on probation continues to have absences or
- The adult learner's grade is below 75% in any course or
- The adult learner's behavior is inappropriate during either the Academic Phase or the Practicum Phase

When a written notice of suspension is sent to an adult learner, a mandatory counseling session is scheduled by and with the Course Director and the Program Director. If necessary, a session may be scheduled between the adult learner, the Course Director, the Program Director and other involved individuals.

A suspended adult learner may, at the discretion of the Course Director and the Program Director, be re-enrolled and retake portions of the course in the next course cycle.

When a counseling session occurs:

- Minutes of the session are taken
- The reason for the counseling session is included in the minutes
- Agreements to improve academic progress and/or modify behavior are documented
- Consequences of continued difficulties are clearly stated and included in the minutes

Dismissal occurs when:

- A re-instated adult learner continues to have absences or
- An adult learner has not kept agreements that were documented at a counseling session to improve academic progress, and/or modify behavior or
- An adult learner exhibits inappropriate behavior at **MMI** or at the Internship Site or
- An adult learner does not complete all course requirements, including academic, practicum, and financial requirements within a three-year time period following **MMI**'s official end of the academic phase in which the adult learner was initially enrolled.



If we were to establish a primary principle, it would be to constantly allow the child's participation in our lives. For he cannot learn to act if he does not join in our actions, just as he cannot learn to speak if he does not hear... To extend to the child this hospitality, to allow him to participate in our work, can be difficult, but it costs nothing. Our time is a far more precious gift than material objects...

María Montessori

Grievance Procedures

Should any adult learner be in disagreement with a policy, action, or decision made by Montgomery Montessori Institute, a conference may be arranged with the Program Director, the Course Director or the appropriate faculty member or practicum site representative to discuss the nature of the disagreement. Every reasonable attempt will be made in a timely manner to reach a satisfactory solution for all parties involved.

Should this rather informal method of meetings not lead to a solution that is mutually satisfactory to all parties, the adult learner must present to the Program Director a brief written summary of his/her disagreement with Montgomery Montessori Institute. Within a fourteen-day period, the Program Director schedules a meeting of the Grievance Committee at a mutually agreeable time. This committee is comprised of the Program Director, the Course Director, two faculty members, **MMI**'s legal counsel, and a member of the student body elected in June at the beginning of each new class cycle. Should any member of the Grievance Committee be directly involved in a dispute brought before the Committee, the involved member does not serve on the Grievance Committee during discussion and resolution of the particular complaint.

The Grievance Committee meets to discuss the dispute and attempts to reach a satisfactory solution to a problem brought before it through thorough evaluation of the situation. Recommendations are made based on deliberation and a majority vote while always adhering to the basic framework of the policies and requirements of Montgomery Montessori Institute and the American Montessori Society. Written notice of recommendations or actions are mailed to the adult learner within seven days following the Grievance Committee meeting.

If the resolution is not acceptable, the adult learner has the right to appeal to the Secretary of Higher Education at the Maryland Higher Education Commission, the American Montessori Society, or MACTE - Montessori Accreditation Council for Teacher Education.

Secretary of Higher Education
MD Higher Education Comm.
6 N. Liberty Street, 10th floor
Baltimore, Maryland 21201
410-767-3301
james.fielder@maryland.gov
www.mhec.maryland.gov

American Montessori
Society
116 East 16th Street
New York, New York 10003
212-358-1250
ams@amshq.org

MACTE
420 Park Street
Charlottesville, VA 22902
434-202-7793
www.macte.org
info@macte.org

Maryland Office of the
Attorney General,
Consumer Affairs Office
200 St. Paul Place
Baltimore, MD 21202
410-576-6300
410-528-8662

The MACTE Commission will review complaints that relate to Montgomery Montessori Institute's compliance with accreditation standards. The Commission is interested in the sustained quality and continued improvement of Montessori teacher education courses, but does not intervene on behalf of individuals or act as a court of appeal for individuals in matters of admission, appointment, promotion or dismissal of faculty, staff or adult learners. A copy of the appropriate accreditation standards and/or the Commission's policy and procedure for submission of complaints may be obtained by contacting the MACTE Commission at the address given above.

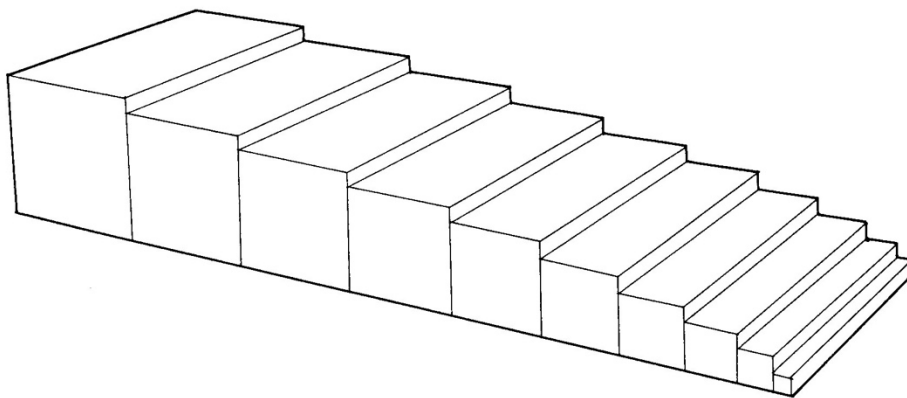

Withdrawal or Dismissal

Adult learners who withdraw or are dismissed from either phase of the course after 50% has been presented are responsible for the full tuition and fees, including any unpaid portion. Refunds cannot be considered after 50% of either phase of the course has been presented.

Adult learners who withdraw from the course after 50% of either phase is presented but before completion are eligible to apply to complete the course within two years following the original enrollment date.

Written permission is required from the Program Director prior to re-admission. Adult learners wishing to apply for re-admission to the course after this two-year time will be considered on an individual basis and at the sole discretion of the Program Director. Tuition for completing the course is prorated and based upon current tuition fees and the percentage of the course to be taken.



Extension Policy

Permission for extensions will be granted by an individual case assessment. A conference may be arranged with the Program Director, the Course Director or the appropriate faculty member or practicum site representative to discuss the nature of the extension. In the case of extenuation circumstances, MMI may offer a adult learner up to three (3) years to finishing the practicum phase and all outstanding assignees required for graduation after completion of the academic phase. Those who do not complete within the three (3) years, will have their file labeled "inactive". Reactivation of the file, will depend on communication with an AMS and MACTE representative. A processing fee may be required.

Cancellation of Courses

If **MMI** should close or discontinue its course, **MMI** shall refund to each currently enrolled adult learner monies paid by the adult learner for tuition and fees and the adult learner shall not be held liable for monies due for tuition and fees to **MMI**. With approval from the Secretary of the Maryland Higher Education Commission, **MMI** will try to help the adult learner continue studies at another approved Montessori Teacher Education Program offering a similar course.



Inclement Weather or Emergencies

Should inclement weather or other emergencies make it necessary to cancel classes, **MMI** will make every attempt to notify each adult learner. Arrangements will be made to reschedule missed classes.

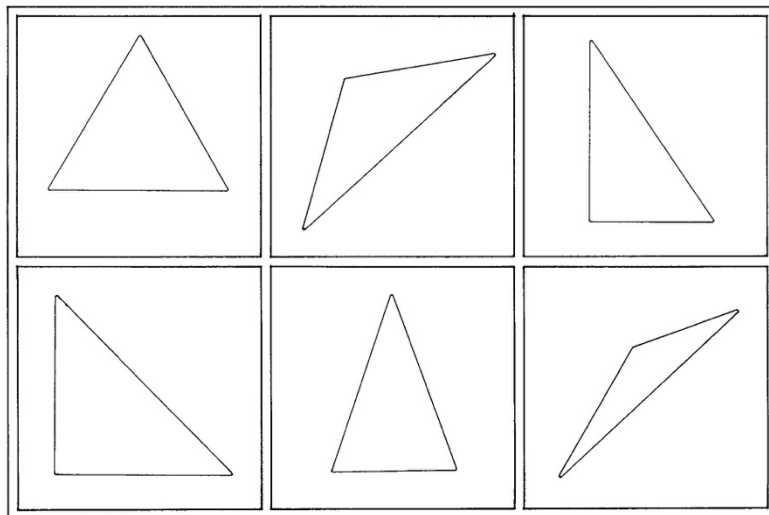

Early Childhood Education Course

MECE-ACAD
(401-414)
Academic Phase

Course Description

During the Academic Phase (MECE-ACAD) the adult learner will receive a total of 291 instructional hours in the following:

MECE-PL 401 Practical Life / Everyday Living Curriculum:

Philosophy and rationale, ground rules to grace and courtesy, control of movement, care of the person, care of the environment, and food and nutrition.

Instructor: Saadia Perwaiz

40 Academic Phase Instructional Hours

MECE-SEN 402 Sensorial Curriculum:

Philosophy and rationale. Use of didactic materials aiding the education and refinement of the senses.

Instructor: Saadia Perwaiz

40 Academic Phase Instructional Hours

MECE-PHIL 403 Montessori Philosophy / Theory:

Overview of Montessori's principals and ideas (to include study of the absorbent mind, sensitive periods, tendencies and the mathematical mind, spiritual and moral development of the child, cosmic education, and peace education) and her view of the child and his/her place in society, with an emphasis on Montessori's concept of the child from birth through six, in relation to Montessori philosophy, materials, teacher, and environment.

Instructors: A. Feledy

40 Academic Phase Instructional Hours

MECE-OB/R 404 Observation & Research Methods in Montessori Education:

Theories and field research techniques used in cultural anthropology and their usefulness in understanding early childhood development in a Montessori setting. Various techniques of observation are addressed. Some assignments in this course will be completed during the Practicum Phase (MECE-PRAC 416 Independent Study).

Instructor: Mary Akatu-Speakman

16 Academic Phase Instructional Hours

MECE-LANG 405 Language Curriculum:

Philosophy and rationale of language, receptive and expressive language experiences, visual and auditory perceptual experiences, vocabulary development and enrichment, use of materials that aid the development of these skills/concepts to include reading, penmanship, writing, and function of words, plus children's literature and drama.

Instructor: Betsy Newman

40 Academic Phase Instructional Hours

MECE-MA 406 Mathematics Curriculum:

Philosophy, rationale and materials that aid in the development of mathematical concepts and skills: introduction to numeration, the decimal system, functions of the decimal system, linear counting, memorization of basic arithmetic facts, fractions, and mathematical applications.

Instructor: Betsy Newman

40 Academic Phase Instructional Hours

MECE-PLS 407 Physical and Life Science Curriculum:

Philosophy and rationale of the Montessori curriculum in regard to botany, zoology, earth science, and physical science.

Instructor: Tory Enerson

10 Academic Phase Instructional Hours

MECE-CD/P 408 Child Development / Psychology:

Theories of development, stages of development, areas of development, and the physical, cognitive, emotional, and social development of the young child. Current research in the field is reviewed.

Instructor: Laveeta Sweeney

32 Academic Phase Instructional Hours

MECE-AR 409 Art Curriculum:

Philosophy and rationale of art. Adult learners are introduced to the basic skills to be presented, two dimensional work such as easel or table work, three dimensional work and art appreciation and history.

Instructor: Heather Love

8 Academic Phase Instructional Hours

MECE-MU 410 Music Curriculum:

Philosophy and rationale, rhythmic skills, singing skills, instrumental skills, music appreciation and history.

Instructor: Julie Billingsley

8 Academic Phase Instructional Hours

MECE-MOV 411 Movement / Fine and Gross Motor Skills Curriculum:

Philosophy and rationale of movement and body awareness in the context of basic skills, such as loco-motor, stationary, games, line activities, story-telling and dramatics with a focus on being in nature.

Instructor: E.Wilson Wulfekotte

4 Academic Phase Instructional Hours

MECE-SS 412 Social Studies Curriculum:

Philosophy and rationale of geography (land and water forms, globes, maps, flags, multicultural awareness) and of history (time, calendar, seasons, and personal history).

Instructor: Tory Enerson

10 Academic Phase Instructional Hours

MECE-MA 413 Classroom Leadership & Parent Involvement/Education:

Classroom Leadership topics include, but are not limited to the following: preparation of the environment, scheduling for the staff as well as the schedule for the child’s day, evaluation of children, techniques for discipline, communication, and problem solving, human needs and requirements (children, families and staff) specific to a full day or extended day program, multi-culture and diversity in all forms, understanding issues relating to school administration, professional relations, and best practices.

The Focus of **Parent Involvement/Education** includes raising the level of awareness, developing the knowledge base, providing options and strategies for collaboration and involvement, and methods of application-implementation of such strategies. Also professional responsibilities, reflective practice, innovation and flexibility, multi diversity and culturally responsive methods, support and intervention for learning differences and community resources for learning, plus licensing requirements, start-up procedures, legal structures of schools, budgeting and financial operations, and the role of consultation and accreditation.

Instructor: Margaret Akatu

20 (10 hours each) Academic Phase Instructional Hours

MECE-OR 414 Orientation:

Facility and course overview.

Program Director: Aline Feledy

1 Hour Orientation

Early Childhood Education Course

MECE-PRAC

(415-417)

Practicum Phase



Course Description

During the Practicum Phase adult learners will complete a minimum of 540 Practicum hours including an internship and monthly Practicum Seminars.

MECE-PRAC 415 Student Teaching: The function of the Practicum Phase is to provide for the adult learner a supervised teaching-learning experience and a period of observation, internalization, and further study, to bring together the theory and practice of Montessori education. The minimum early childhood practicum is defined as lasting a full academic year, with the adult learner working at the practicum site, in the classroom of an approved Supervising Teacher, for a minimum of three hours a day, five days a week for nine consecutive months (or other equivalent time as approved by AMS, MACTE, and **MMI**).

No part of the Practicum Phase may precede the beginning of the Academic Phase of the course. The class should contain children in the 2 1/2 - 6 year age range and should be equipped with a full complement of Montessori didactic equipment. The adult learner in a traditional internship may not be asked to assume the full responsibility of the classroom without the presence of the Supervising Teacher or other qualified staff person. Adult learners qualifying for a Self-Directed Practicum require a minimum of three on-site consultation visits by a field consultant plus documented additional support.

Total: 540 hours minimum

MECE-PRAC 416 Independent Study: The adult learner will undertake an original Independent Study that is ongoing during the Practicum Phase of the Early Childhood teacher education course. The Independent Study includes observation and research, analysis of field data, and preparation and presentation of the completed research paper. The formal research presentation to colleagues and **MMI** faculty concludes the Observation & Research Methods in Montessori Education Course begun during the Academic Phase.

Total: 16 instructional hours minimum

MECE-PRAC 417 Practicum Seminars: Adult learners are required to participate in Practicum Seminars as listed in the **MMI** calendar throughout the Practicum Phase.

Total: 70 hours approximately

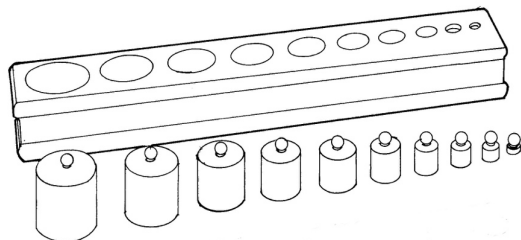

Early Childhood Academic Phase

MECE-ACAD (401-414)

Course Schedule

Week of:		Monday	Tuesday	Wednesday	Thursday	Friday
June 12	am	Orientation/ Overview	Philosophy/ Pedagogy	Philosophy/ Pedagogy	Philosophy/ Pedagogy	Philosophy/ Pedagogy
	pm	Philosophy/ Pedagogy	Philosophy/ Pedagogy	Philosophy/ Pedagogy	Philosophy/ Pedagogy	Philosophy/ Pedagogy
June 19	am	Observation & Research Methods	Observation & Research Methods	(2) Music (2) Environ. Des	(2) Music (2) Environ. Des	Montessori Theory/ Philosophy Exam
	pm	Observation & Research Methods	Observation & Research Methods	(2) Art (2) Environ. Des	(2) Music (2) Environ. Des	Movement Persl Growth & Develop
June 26	am	Child Development	Child Development	Child Development	Child Development	Practical Life
	pm	Child Devpt - spiritual	Child Development	Child Development	Child Development	Practical Life
July 3	am	Practical Life	Holiday	Practical Life	Practical Life	Practical Life
	pm	Practical Life	Independance Day	Practical Life	Practical Life	Practical Life
July 10	am	Sensorial	Sensorial	Sensorial	Sensorial	Sensorial
	pm	Sensorial	Sensorial	Sensorial	Sensorial	Sensorial
July 17	am	Math	Math	Math	Math	Math
	pm	Math	Math	Math	Math	Math
July 24	am	Language	Language	Language	Language	Language
	pm	Language	Language	Language	Language	Language
July 31	am	Classroom Leadership	Classroom Leadership	Classroom Leadership	Social Studies	Physical &Life Sciences
	pm	Classroom Leadership	Classroom Leadership	Social Studies	Physical &Life Sciences	Physical &Life Sciences

Course sequence is subject to change at the discretion of the Course Director.



Montgomery
Montessori
Institute

Shaping The Future Of Education

Early Childhood Practicum Phase Internship Seminars MECE-PRAC (415-417)

As determined by Adult Learner and MMI

Academic Phase Fall Session Practicum Seminars

*Dates to be announced — 8 am to 4 pm (working lunch)

	am	pm
Sept	Practical Life	Practical Life
Oct.	Math	Language
Nov.	Recognizing Special Needs and Symptoms of Abuse & Neglect	Recognizing Special Needs and Symptoms of Abuse & Neglect
Dec.	Make up session	
Jan.	Observation and Research	Personal Growth and Development
Feb.	Sensorial	Sensorial
March	Math	Language
April	Social Studies/Science Interest Projects	
May	Personal Growth and Development	Leadership: Inclusion and Anti Bias in a Montessori classroom
May	Exam Review	
June	Research Paper Presentations	Preparation of Practicum and Written Exam

Summer 2024 Early Childhood Exam Schedule

	Monday June 24	Tuesday June 25	Wednesday June 26	Thursday June 27
9-12	Practical Life Curriculum Oral Exams	Sensorial Curriculum Oral Exams	Math Curriculum Oral Exams	Language Curriculum Oral Exams
12-1	Lunch Break	Lunch Break	Lunch Break	Lunch Break
1-5	Practical Life Curriculum Oral Exams	Sensorial Curriculum Oral Exams	Math Curriculum Oral Exams	Language Curriculum Oral Exams Evening Graduation

Schedule subject to change at the discretion of the Course Director.

Infant & Toddler Education Course

MITE-ACAD

Academic Phase

Course Description

The Academic Phase (MECE-ACAD) consists of 254 classroom hours (plus, if needed, the 24-hour Overview Course for adult learners not holding a prior Montessori credential). Portions of the Courses listed below continue into the Practicum Phase.

MITE-OV 6.1.5.0. Early Childhood Overview Course:

Adult learners who do not hold a Montessori Credential complete a 24-hour overview of the Montessori philosophy for children 2½ through 6 years to include the rationale and basic methodology for the materials in the curriculum areas of Practical Life, Sensorial, Language and Mathematics. (The Early Childhood Overview Course hours are not included as part of the total academic contact hours required for the course.)

Instructors: Betsy Newman, Saadia Perwaiz

24 hours

MITE-CD 6.1.5.1. Child Development: Prenatal to 3 Years:

Prenatal development and childbirth are examined plus consideration of the social, emotional/psychological, cognitive, physiological, and spiritual development of the young child. This course includes Maria Montessori's ideas as well as those of major contemporary theorists.

Instructors: Laveeta Sweeney

48 Academic Phase Instructional Hours

MITE-PHIL 6.1.5.2. Montessori Philosophy:

Overview of Montessori's principals and ideas (to include study of the absorbent mind, sensitive periods, tendencies and the mathematical mind, spiritual and moral development of the child, cosmic education, and peace education) and her view of the child and his/her place in society, with an emphasis on Montessori's concept of the children from birth to 3. Scientific analysis of how to nurture and assist the unfolding of the human personality including care of physical and psychological needs, daily routines as curriculum, strategies for assistance, interactional techniques with children, developmental assessment and record keeping, and positive communication with emphasis on personal development of the adult based on Montessori's view of the child. A 1-hour welcome introduction to the Program is included.

Instructors: Aline Feledy

40 Academic Phase Instructional Hours

MITE-ED 6.1.5.3. Environmental Design:

This course examines the many critical factors that impact the infant and toddler environment: aesthetics, ages and age groupings, numbers and ratios of children, safety considerations, and various legislative issues. Plus meeting the needs of the sensitive periods for Language, Movement, Development of the Senses, Independence, and Order, etc., will be explored through use of appropriate activities, space, and materials.

Instructors: Boulet, Feledy, Horton, Sweeny

34 Academic Phase Instructional Hours

MITE-PED 6.1.5.4. Pedagogy:

Scientific analysis of how to nurture and assist the unfolding of the human personality including care of physical and psychological needs, daily routines as curriculum, strategies for assistance, interactional techniques with children, developmental assessment and record keeping, and positive communication with emphasis on personal development of the adult based on Montessori's view of the child.

Instructors: Elyssa Boulet, Gwendolyn Horton

38 Academic Phase Instructional Hours

MITE-CFC 6.1.5.5. Child, Family, and Community:

Adult learners must develop a close parent/child relationship based upon mutual cooperation and support. Topics covered include the psychology of parenthood and effective methods of communicating child-rearing practices to the home; dialogue skills necessary for effective teacher-parent conferencing, parent involvement and education; locating professional resources in the community; and an understanding of the critical role health and nutrition play in growth and development.

Instructor: Diana Hasham

16 Academic Phase Instructional Hours

MITE-OB 6.1.5.6. Observation and Research Methods in Montessori Education:

Various techniques of observation are addressed. The remaining part of class consist of **MMI** staff supervised observations of a balance of infant and toddler settings. A minimum of four documented observations of children from birth to age three are required during the Practicum Phase. Observations can take place in various community settings, Montessori programs, clinical settings, or in home environments. At least one observation must be at the infant level, and at least one must be at the toddler level. The course director may assign the other two observations. NOTE: Lab: 12 hours take place during the Practicum Phase.

Instructor: Mary Akatu-Speakman

20 hours total, with 10 Academic Phase Instructional Hours

Completed During the Practicum Phase**MITE-PGD 6.1.5.7. Personal Growth and Development:**

The following topics will be analyzed: professionalism, introspection & reflective practice, innovation and flexibility, the continued spiritual growth of the adult learner, and the role of ethical behavior.

Instructor: E. Wilson Myers-Wukekott

16 Practicum Phase Instructional Hours

MITE-PGL 6.1.5.8. Program Leadership:

Topics include preparation of the environment, scheduling for the staff, as well as the schedule for the child's day, and evaluation of the children. Techniques for discipline, communication and problem-solving in the classroom. Human needs and requirements for children, families and staff specific to a full day or extended day program. Multi-culture and diversity, including special needs and learning styles. Understanding issues related to school administration, professional relationships and best practices.

Instructors: Aline Feledy, Gwendolyn Horton

16 Practicum Phase Instructional Hours

*The most important period of life
is not the age of university studies
but the period from birth to the age of six...
for that is the time when intelligence itself,
her greatest implement, is being formed...*

María Montessori

Infant & Toddler Education Course

MITE-PRAC

Practicum Phase

Course Description

During the Practicum Phase adult learners will complete: a 540 hour minimum internship, an Independent Study Project requiring at least 24 hours, a minimum of 16 hours in Practicum Seminars and 16 hours of course work for a total of 596 hours. An additional 24 hours is required for those who must complete the Overview Course.

MITE-PRAC 6.1.5.8 Student Teaching: The function of the Practicum Phase is to provide for the student a supervised teaching-learning experience and a period of observation, internalization, and further study, to bring together the theory and practice of Montessori education. Adult learners may choose an Infant Concentration at a site where they work with infants and children up to eighteen months of age or they may choose the Toddler Concentration in a setting where the children range in age from eighteen months to three years of age. The Model 3 Practicum, Infant and Toddler (birth to three years) is designed for the adult learner whose primary interest is the care and development of infants and toddlers. The adult learner will follow the development of children in the class, establish relationships with the children and their families, make and present materials, participate in planning activities, record keeping, observation, class management, and promote parent involvement and education. The minimum Infant & Toddler practicum is defined as lasting a full academic year, with the adult learner working at the practicum site, under the direction of an approved Supervising Teacher, for three hours a day, five days a week for nine consecutive months (or other equivalent time as approved by AMS and **MMI**).

No part of the Practicum Phase may precede the beginning of the Academic Phase of the course. The setting should contain children ranging in age from birth to eighteen months or eighteen months to three years of age and should be in a well-equipped setting with a variety of age appropriate Montessori didactic equipment. The adult learner may not be asked to assume the full responsibility of the classroom without the presence of the Supervising Teacher or other qualified staff person. Adult learners qualifying for a Self-Directed Practicum require a minimum of three on-site consultation visits by a field consultant plus documented additional support.

Total: 400 hours minimum

MITE-PRAC 6.1.5.9 Practicum Seminars: Adult learners are required to participate in Practicum Seminars and additional course work as listed in the **MMI** calendar throughout the Practicum Phase. If required, the additional 24 hours of the Overview course will be required during the Practicum Phase.

Total: 16 hours minimum (40 hours with Overview course)

MECE-PRAC 6.1.5.10 Independent Study: The adult learner will undertake an original Independent Study that is ongoing during the Practicum Phase of the Infant & Toddler teacher education course. The Independent Study includes observation and research, analysis of field data, and preparation and presentation of the completed research paper. The formal research presentation to colleagues and **MMI** faculty concludes the Observation & Research Methods in Montessori Education Course begun during the Academic Phase.

Total: 24 hours minimum

2023-2024 Infant & Toddler Schedule of Classes MITE-ACAD

Academic Phase Summer Session

Week of:		Monday	Tuesday	Wednesday	Thursday	Friday
June 12	a m	Orientation/ Overview	Philosophy/ Pedagogy	Philosophy/ Pedagogy	Philosophy/ Pedagogy	Philosophy/ Pedagogy
	p m	Philosophy/ Pedagogy	Philosophy/ Pedagogy	Philosophy/ Pedagogy	Philosophy/ Pedagogy	Philosophy/ Pedagogy
June 19	a m	Observation & Research Methods	Observation & Research Methods	(2) Music (2) Environ. Des	(2) Music (2) Environ. Des	Movement Persl Growth & Develop
	p m	Observation & Research Methods	Observation & Research Methods	(2) Art (2) Environ. Des	(2) Music (2) Environ. Des	Montessori Theory/ Philosophy Exam
June 26	a m	Child Development	Child Development	Child Development	Child Development	Child Dev. Prenatal
	p m	Child Development	Child Development	Child Development	Child Development	ChChild Dev. Prenatalild Devpt - spiritual
July 3	a m	Infant Care	Holiday	Infant Care	Infant Care Environ. Design	Infant Care Child devlp
	p m	Infant Care	Independance Day	Infant Care	Infant Care Child devlp	Infant Care Child devlp
July 10	a m	Toddler Pedagogy	Toddler Pedagogy	Toddler Pedagogy	Toddler Environ. Design	Leadership discipline, comm
	p m	Toddler Pedagogy	Toddler Pedagogy	Toddler Environ. Design	Toddler Environ. Design	C,F,C: Parent Communication

*Course sequence is subject to change at the discretion of the Course Director.



Montgomery
Montessori
Institute

Shaping The Future Of Education

**Infant & Toddler Practicum Phase
Internship Seminars and Exam Schedule
MITE-PRAC
(6.1.5.8 – 6.1.5.10)**

Academic Phase Fall Session Practicum Seminars

*Dates to be announced — 8 am to 4 pm (working lunch)

	am	pm
Sept	Leadership – Mock Day, Discipline, Communication	Leadership / Shopping Day
Oct.	Personal Growth & Development	Leadership – Understanding Issues Related to School Admin.
Nov.	Recognizing Special Needs and Symptoms of Abuse & Neglect	Recognizing Special Needs and Symptoms of Abuse & Neglect
Dec.	December: Exam , Date to be announced	
Jan.	Observation and Research	Personal Growth and Development
Feb.	Prerequisite EC Overview Course	Prerequisite EC Overview Course
March	Prerequisite EC Overview Course	Prerequisite EC Overview Course
April	Prerequisite EC Overview Course	Prerequisite EC Overview Course
May	Personal Growth and Leadership	Leadership: Inclusion and Anti Bias in a Montessori classroom
June	Research Paper Presentations	Preparation of Practicum and Written Exam

2024 Exam Schedule

	a.m.	p.m.
December TBD	Infant – 18 months Child Development Philosophy & Pedagogy Environmental Design Oral Practicum Exams	
Thursday, June 27	Infant Theory Written Exams & Toddler Oral Exams	Evening Graduation



MACTE Competencies

The Adult Learner Understands the Following:

- I. Content Knowledge
 - 1a. Montessori Philosophy
 - 1b. Human Growth and Development
 - 1c. Subject matter for each Course Level
 - 1d. Community Resources for Learning

- II. Pedagogical Knowledge
 - 2a. Correct Use of Montessori Materials
 - 2b. Scope and Sequence of Curriculum
 - 2c. The Prepared Environment
 - 2d. Parent / Teacher / Family / Community Partnership
 - 2e. The Purpose and Methods of Observation
 - 2f. Planning for Instruction
 - 2g. Assessment & Documentation
 - 2h. Reflective Practice
 - 2i. Support and Intervention for Learning Differences
 - 2j. Culturally Responsive Methods

- III. Practice
 - 3a. Classroom Leadership
 - 3b. Authentic Assessment
 - 3c. The Montessori Philosophy and Methods (Materials)
 - 3d. Parent / Teacher / Family Partnership
 - 3e. Professional Responsibilities
 - 3f. Innovation and Flexibility

CODE OF ETHICS OF THE AMERICAN MONTESSORI SOCIETY

Adopted by the AMS Board of Directors October 1969. Expanded June 1975. Updated October 2008 and 2010.

As American Montessori Society members, we pledge to conduct ourselves professionally and personally, in ways that will reflect our respect for each other and for the children we serve. We will do whatever is within our talents and capacity to protect the right of each child to have the freedom and opportunity to develop his/her full potential.

PRINCIPLE I ~ Commitment to the Student

In fulfillment of the obligation to the children, the educator:

1. Shall encourage independent action in the pursuit of learning
2. Shall protect the opportunity to provide for participation in educational programs without regard to race, sex, color, creed or national origin
3. Shall protect the health and safety of students
4. Shall honor professional commitments, maintain obligations and contracts while never soliciting nor involving students or their parents in schemes for commercial gain
5. Shall keep in confidence information that has been secured in the course of professional service, unless disclosure serves professional purposes or is required by law

PRINCIPLE II ~ Commitment to the Public

The Montessori educator shares in the responsibility for the development of policy relating to the extension of educational opportunity for all and for interpreting educational programs and policies to the public.

In fulfilling these goals, the educator:

1. Shall support the American Montessori Society and not misrepresent its policies in public discussion. Whenever speaking or writing about policies, the educator should take the precaution to distinguish his private views from the official position of the Society
2. Shall not interfere with nor exploit the rights and responsibilities of colleagues within the teaching profession

PRINCIPLE III ~ Commitment to the Profession

The Montessori educator makes efforts to raise professional standards and conditions to attract persons worthy of trust to careers in Montessori education.

In fulfilling these goals the educator:

1. Shall extend just and equitable treatment to all members of the Montessori education profession
2. Shall represent his or her own professional qualification with clarity and true intent
3. Shall apply for, accept, offer, recommend, and assign professional positions and responsibilities on the basis of professional preparation and legal qualifications
4. Shall use honest and effective methods of administering duties, use of time, and conducting business



"You must know that there is nothing higher, or stronger, or sounder, or more useful afterwards in life, than some good memory, especially a memory from childhood, from the parental home. You hear a lot said about your education, yet some such beautiful, sacred memory, preserved from childhood, is perhaps the best education. If a man stores up many such memories to take into life, then he is saved for his whole life. And even if only one good memory remains with us in our hearts, that alone may serve some day for our salvation."

...Dostoevsky, The Brothers Karamazov

FUNDAMENTAL TENETS OF AN AMS-AFFILIATED TEACHER EDUCATION PROGRAM

AMS Teacher Education Action Commission (TEAC), Revised October 2017

1. **Cosmic Education:** provides the framework for each individual to answer the question, “Who am I and why am I here?” Teacher education of all levels mirrors the underpinnings of cosmic education with consistent attention to repeated and expanding experiences leading to an appreciation of the web of relationships that is the universe, through an understanding of:
 - the interconnectedness of all things
 - wonder and respect for the living and non-living world
 - nurturing the spirit of the children and the adolescent
 - indirect and direct preparation of each activity
 - sequencing based on whole-to-part-to-whole pathway
 - integrated spiral curriculum
 - awareness that the universe is an evolving, self-organizing force that offers many possibilities and is impacted by our actions.
2. **Transformation of the Adult:** is an essential outcome of the teacher education course, with an emphasis on spiritual preparation, service to humanity, and the attitudes and dispositions inherent in the philosophy.
3. **Education for Peace:** is the ultimate task of Montessori education. Intentional, peaceful communities of learners cultivate: respect for all humanity, appreciation of world cultures, and the valuing of diversity, social justice and equality. These communities exercise trust and peaceful ways of addressing conflict and working together.
4. **Respect:** for oneself, others, and for the environment is fostered in all interactions.
5. **The Prepared Environment:** fosters teaching and learning through interactions with individuals and materials at the level of the course.
6. **Constructivist Theory:** applies to all levels of Montessori Education. Individuals of different ages actively construct knowledge through enriching interchanges and experiences with others and the physical environment.
7. **Modeling:** movement, choice, peer teaching, dispositions, commitment to service, and reflective practices by teacher educators and mentors occurs so adults observe and experience Montessori theory in action.
8. **Observation:** is of vital importance to the teaching and learning process. Teacher education programs communicate the necessity to develop increasing observation skills in one’s own classroom and other classroom environments. Record keeping documents the on-going observations and learning outcomes that become the basis for future planning.
9. **Assessments:** are part of the teaching and learning cycle. Various formats meet learners where they are and guide them forward to meet the competencies of an effective Montessori teacher.
10. **An Extended Practicum Phase:** provides the adult learner with a teaching and learning experience under the guidance of a mentor. Observation, specific feedback, internalization, and further study guides Montessori theory into practice.
11. **The Continuum of Development:** across time, place and culture is honored through equal appreciation of all program levels who learn from each other and respect the contributions of Montessori pioneers, leaders, and practicing and aspiring teachers.
12. **Lifelong Learning:** is inspired by the teacher education program as part of the on-going personal and professional journey of learning, growing, observing, reflecting, and researching.



Text Books

- Cohen, D, Stern, V., & Balaban, N. (2008) *Observing and recording the behavior of young children*. New York: Teachers College Press.
- Mooney, Carol Garhart. (2012) *Theories of childhood: An introduction to Dewey, Montessori, Erikson, Piaget, & Vygotsky*. Minnesota: Relief Press.
- Montessori, Maria. (1946/1989) *Education for a new world*. Oxford, England: Clio Press.
- Montessori, Maria. (1949/1988) *The absorbent mind*. Oxford, England: Clio Press.
- Montessori, Maria. (1912/1997) *The discovery of the child*. Oxford, England: Clio Press.
- Montessori, Maria. (2007) *The Formation of Man*. Amsterdam, The Netherlands: Montessori-Pierson Publishing.
- Montessori, Maria. (1966) *The secret of childhood*. New York: Ballantine Press.
- Standing, E.M. (1957) *Maria Montessori - Her life and work*. New York: Penguin Books.
- Wolf, Aline D. (1996) *Nurturing the spirit*. Pennsylvania: Parent Child Press.

Additional Books for Infants & Toddlers

- Gerber, Magda. (1998) *Your self-confident baby - How to encourage your child's natural abilities*. California: John Wiley & Sons.
- Kovach, Beverly & Denise DaRoss-Voseles. (2009) *Being with babies*. Beltsville, Maryland: Gryphon House

Additional suggested readings:

- Barnett, Regina Reynolds. (1981) *Let our the sunshine - A Montessori approach to creative activities*. Dubuque, Iowa: Wm. C. Brown Company Publishers.
- Chattin-McNichols, John. (1992) *The Montessori controversy*. New York: Delmar Publishers.
- Hammond, Ruth Anne. (2009) *Respecting babies: A new look at Magda Gerber's RIE approach*. Washington, DC: Zero to Three.
- Kramer, Rita. (1976/1998) *Maria Montessori, a biography*. Addison-Wesley Publishing Co. 1983.
- Lillard, Angeline Stol. (2004) *Montessori: the science behind the genius*. New York: Schocken Books.
- Lillard, Paula Polk. (1996) *Montessori today*. New York: Schocken Books.
- Montessori, Maria. (1955/1989) *The formation of man*. Oxford, England: Clio Press.



Please sign and return this page to Montgomery Montessori Institute.

I acknowledge receipt of the Adult Learner Handbook

Signature _____ Date _____

Please submit any questions: